

Machine Model #: _____
 Machine Capacity: _____

Fax: 913-227-0523
 SPECIAL ORDER NON RETURNABLE

PROPRIETARY AND CONFIDENTIAL
 THE INFORMATION CONTAINED IN THIS DRAWING IS THE SOLE PROPERTY OF ARROW MATERIAL HANDLING. ANY REPRODUCTION IN PART OR AS A WHOLE WITHOUT THE WRITTEN PERMISSION OF ARROW MATERIAL HANDLING IS PROHIBITED.

Date: _____
 Sales Rep: _____
 Company Name: _____
 Customer Name: _____
 Phone: _____

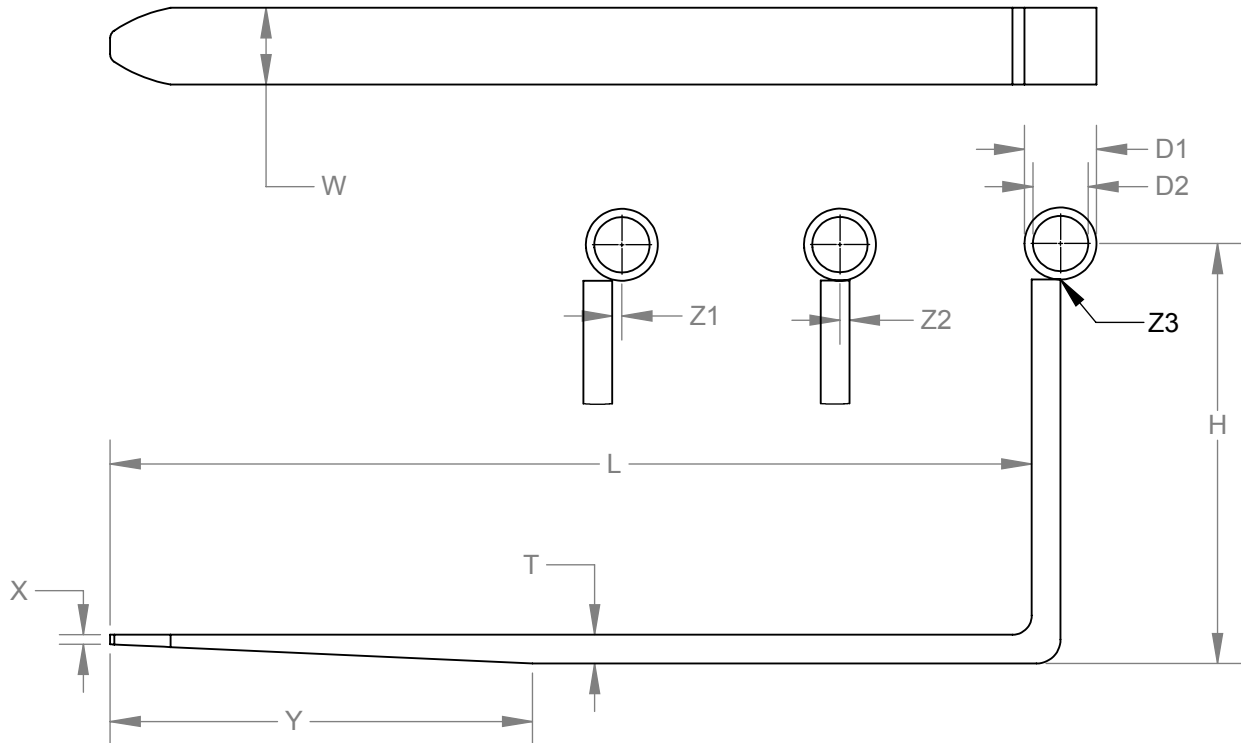

T	
W	
L	
Y	Standard / Full Taper / Polished
X	Standard / Chisel Point
D1	
D2	
H	
Z	Z1:___ / Z2:___ / Z3

Shaft Dia _____

Price per Pair \$: _____
 Estimated Lead Time: _____
 Customer Signature: _____ Date: _____



TITLE:
 Shaft (PIN) Type Fork

	NAME	DATE
DRAWN	VS	26 Dec 13
CHECKED		
ENG APPR.		
MFG APPR.		
Q.A.		

SIZE DWG. NO. REV
A Form-OF-003B 2
 23 Sep 14
 SCALE: 1:10 SHEET 1 OF 1

Rev	By	Date	Description
2	VS	23 Sep 14	Format update
1	VS	14 Mar 14	Added fax number, added shaft dia block, added Z1 and Z2 block